



---

# INTERNATIONAL FIRE CONSULTANTS LTD

---



## COMMERCIAL IN CONFIDENCE

*This document is provided for the purpose of demonstrating compliance with the appropriate performance levels required by a designated third party.*

*It should not be divulged to any other parties without the approval of the client named below.*

*This document remains the property of the client.*

## FIELD OF APPLICATION REPORT IFCA/08016

**Field of Application of the fire resistance of  
Contraflam Lite 30 glass panes as single panes  
and incorporated in IGU's, within metal frames  
when evaluated in accordance with EN 1364-1**

Prepared on behalf of:

Vetrotech Saint-Gobain Int. AG  
Stauffacherstrasse 128  
CH-3000 Bern 22  
Switzerland

**NOTE:** *This report should not be manipulated, abridged or otherwise presented without the written consent of International Fire Consultants Ltd*

Ref: X/Assess/2008/08016/#7652B

July 2008

---

### International Fire Consultants Ltd

Head & Registered Office: 20 Park Street, Princes Risborough, Buckinghamshire, England HP27 9AH

Tel: +44(0)1844 275500, Fax: +44(0)1844 274002, E-mail: [ifc@intfire.com](mailto:ifc@intfire.com)

Registered No: 2194010 England

An International Fire Consultants Group Company

## ISSUE RECORD

| Issue    | Date     | Recipient                      | Comments                                 |
|----------|----------|--------------------------------|--|
| Original | 07/07/08 | Vetrotech Saint-Gobain Int. AG | In electronic (pdf) and hard copy format |
|          |          |                                |  |
|          |          |                                |  |
|          |          |                                |  |
|          |          |                                |  |
|          |          |                                |  |

## AMENDMENT RECORD

| Date | Paragraph | Amendment |
|------|-----------|-----------|
|      |           |           |
|      |           |           |
|      |           |           |
|      |           |           |
|      |           |           |
|      |           |           |
|      |           |           |
|      |           |           |

|                 |                   |  |  |  |  |  |
|-----------------|-------------------|--|--|--|--|--|
| <b>Revision</b> | <b>IFCA/08013</b> |  |  |  |  |  |
| Author          | HW                |  |  |  |  |  |
| Reviewer        | PEJ               |  |  |  |  |  |

# CONTENTS

|   |           |
|---|-----------|
| <b>1. INTRODUCTION</b>  | <b>4</b>  |
| <b>2. PROPOSAL</b>  | <b>4</b>  |
| 2.1 CONTRAFLAM LITE 30 GLASS PANES  | 5         |
| 2.2 GLAZING SYSTEM OR METHOD OF GLAZING   | 7         |
| <b>3. TEST EVIDENCE</b>   | <b>8</b>  |
| 3.1 TEST 2007-EFECTIS-R0861   | 8         |
| 3.2 TEST IFCI/577   | 9         |
| 3.3 TEST IFCI/544   | 11        |
| 3.4 TEST WFRC No. 134116  | 12        |
| <b>4. ANALYSIS</b>  | <b>13</b> |
| 4.1 THE TECHNOLOGY OF INSULATED GLASSES   | 13        |
| 4.2 THE INFLUENCE OF THE INTERLAYER THICKNESS                                       | 14        |
| 4.3 THE INFLUENCE OF THE GLASS THICKNESS  | 14        |
| 4.4 OVERVIEW OF TEST EVIDENCE   | 14        |
| 4.5 INTEGRITY PERFORMANCE OF THE GLASS PANES  | 15        |
| 4.6 RADIATION PERFORMANCE   | 15        |
| 4.7 CONSTRUCTION OF THE ENVELOPES OF MAXIMUM PANE SIZES                             | 18        |
| 4.8 DIRECTION OF EXPOSURE   | 19        |
| 4.9 INSULATING DOUBLE GLAZED UNITS (IGU's) VERSUS SINGLE CONTRAFLAM LITE 30 GLAZING | 19        |
| 4.10 LONGITUDINAL THERMAL EXPANSION   | 20        |
| 4.11 FILMS APPLIED TO THE FREE VISION AREA OF CONTRAFLAM LITE 30 GLASS PANES        | 21        |
| <b>5. CONCLUSION</b>  | <b>22</b> |
| <b>6. LIMITATIONS</b>   | <b>23</b> |
| <b>7. VALIDITY</b>  | <b>24</b> |
| <b>APPENDIX A</b>   | <b>25</b> |
| OVERVIEW TEST EVIDENCE  |           |
| <b>APPENDIX B</b>   | <b>26</b> |
| FIGURES IFCA/08016/01 TO 12   |           |

## 1. INTRODUCTION

This report has been produced by International Fire Consultants Ltd (IFC) for our assessment of the fire resistance of Contraflam Lite 30 glass installed as single panes and as part of Insulating Double Glazed Units (IGU's), with various dimensions and glass pane thicknesses, when installed in uninsulated steel framed screens. IFC have performed the evaluations/analysis, and preparation of the Field of Application report, on the instruction of Vetrotech Saint-Gobain International AG.

Fire resisting assemblies are rarely supplied in an identical form to that which was tested. The specification will invariably require the construction to be supplied at a size, in a mode, with glazing apertures, frames, etc. which are different from that tested. The result of a fire resistance test can apply to variations in configurations/construction as long as they do not reduce the performance to one which is below that specified. The influence of those variations is covered by a judgement, sometimes made by the approving authority.

Where the approving authority does not feel technically able to make such judgements, or does not wish to take responsibility for them, then a third party expert opinion is often sought. Such an opinion is often expressed in the form of an assessment of the performance, which may be supported by numerical/quantifiable methods or may be purely an expert judgement.

When establishing the variations in the construction that can achieve the required fire resistance performance, International Fire Consultants Ltd follow the guidance given in BS.ISO/TR12470: 1998, *"Fire resistance tests - Guidance on the application and extension of results"*.

The Field of Application is based upon the constructional information supplied to us (detailed in Section 2) and upon the fire resistance test evidence for parts of the constructions (detailed in Section 3). A full analysis of the fire resistance performance of these assemblies is presented in Section 4.

## 2. PROPOSAL

It is proposed that this Field of Application Report shall establish the fire resistance performance of Contraflam Lite 30 glass installed as single panes and as a part of Insulating Double Glazed Units (IGU's), with various dimensions and glass pane thicknesses when installed in uninsulated steel framed screens, if they were to be tested to the integrity criteria of EN 1364-1:1999 *"Fire resistance tests for non-loadbearing elements – Part 1: Walls"*.

The assessed Contraflam Lite 30 glass panes with various dimensions and glass pane thicknesses are generally based upon details shown on the drawings and/or schedules provided by Vetrotech Saint-Gobain International AG, copies of which are kept on file by IFC for reference and important ones of which are reproduced herein. The construction and details of the assemblies are summarised in Sections 2.1 and 2.2, below, but the documents should be read in conjunction with this report for full interpretation. See **Figures 08016/01** and **02** for a typical glazed screen construction.

Anyone using this report should verify that copies of documents in their possession match those copies which are kept on file by IFC. If variations occur between details described, herein, and those on the relevant documents, the former shall take precedence, or IFC should be contacted for clarification. Refer to Section 6 for recommendations with respect to audit and verification of the manufactured/installed assemblies.

## **2.1 Contraflam Lite 30 Glass panes**

This Field of Application report determines the required glass pane thickness as a function of the Contraflam Lite 30 pane dimensions. See **Figures 08016/04** and **05** for two typical glass-build-ups. The Contraflam Lite 30 glass panes are proposed with pane constructions, maximum dimensions and maximum glass pane areas, as follows:

### ***2.1.1 Single pane applications***

#### Contraflam Lite 5-3-5

- Glass pane thickness:  $\geq 13\text{mm}$
- Glass pane construction: 5mm tempered glass, 3mm interlayer, 5mm tempered glass
- Maximum pane area:  $4.50\text{m}^2$
- Maximum dimensions:
- Height: 3000mm, associated width 1500mm.
- Width: 3000mm, associated height 1500mm.

#### Contraflam Lite 6-3-6

- Glass pane thickness:  $\geq 15\text{mm}$
- Glass pane construction: 6mm tempered glass, 3mm interlayer, 6mm tempered glass
- Maximum pane area:  $6.30\text{m}^2$
- Maximum dimensions:
- Height: 3500mm, associated width 1800mm.
- Width: 3500mm, associated height 1800mm.

#### Contraflam Lite 8-3-8

- Glass pane thickness:  $\geq 19\text{mm}$
- Glass pane construction: 8mm tempered glass, 3mm interlayer, 8mm tempered glass
- Maximum pane area:  $8.74\text{m}^2$
- Maximum dimensions:
- Height: 3800mm, associated width 2300mm.
- Width: 3800mm, associated height 2300mm.

### **2.1.2 Insulated Glazed Unit (IGU) construction**

All glass panes specified above can also be installed as IGU (Insulating Double Glazed Units). The width of the spacer is  $\geq 6\text{mm}$  and the thickness of the secondary glass required, to create the insulating double glazed unit (IGU), is  $\geq 4\text{mm}$ . The glass sheets may consist of:

- Float glass, thickness  $\geq 4\text{mm}$
- Tempered glass, thickness  $\geq 5\text{mm}$ .
- Tempered patterned glass, thickness  $\geq 6\text{mm}$ .
- Laminated safety glass, thickness  $\geq 8\text{mm}$ .

Individual panes can be tinted, coated or surface treated.

Tempered glass is manufactured in accordance with EN 12150 or EN 14179. Laminated glass is manufactured in accordance with EN 14449 or EN 12543.

Patterned glass types are:

- SGG SR SILVIT
- SGG SR ARENA C
- SGG MASTER-POINT
- SGG MASTER-LIGNE
- SGG MASTER-CARRE
- SGG MASTER-RAY
- SGG MASTER-LENS

The interlayer of the Contraflam Lite 30 glass panes has a thickness  $\geq 3\text{mm}$ .

The edge compound of the Contraflam Lite 30 glass panes is in accordance with VSGI standards. This is confidential information and kept on file by IFC.

It is proposed that adhesive/adherent polyester/polyethylene terephthalat (PET) or polyvinyl chloride (PVC) films may be applied to the free vision area of a glazed element. The thickness of the film is within  $25\mu\text{m}$  and  $250\mu\text{m}$ .

It is proposed that Contraflam Lite 30 fire resisting glass panes installed as single glazing and as Insulated Double Glazed Units (IGU's) may be used to achieve 30 minutes fire resistance according to the integrity criteria of EN 1364-1, when glazed into a multi-pane screen constructed from steel sections provided that the method of glazing complies with Section 2.2.

It is also proposed that Contraflam Lite 30 fire resisting glass panes installed as single glazing and as Insulated Double Glazed Units in uninsulated steel frames may be used to achieve 30 minutes fire resistance according to the radiation criterion of  $15\text{ kW/m}^2$  at a distance of 1m from the glazed screen.

## 2.2 Glazing System or Method of Glazing

This Field of Application Assessment Report considers the performance of the proposed glass when installed in accordance with the following glazing system methods:

- a) Any framing system which is used with Contraflam Lite 30 fire resisting glass panes to achieve 30 minutes fire resistance has existing test and/or assessment evidence to support its use for 30 minutes fire resisting applications in accordance with EN1364-1, as appropriate, with another insulating glass of similar composition, i.e. a multiple intumescent interlayer type.
- b) The edge cover on each pane and at each edge is restricted to  $15 \pm 1$ mm in all cases.
- c) The frame is a rectangular tubular steel section with a minimum wall thickness of 1.5mm.
- d) The frame has a face width of 20-60mm and a depth, face to face, of 50-150mm.
- e) The method of joining frame members has been previously tested and/or assessed for 30 minute fire resisting applications in accordance with EN1364-1.
- f) The frame may incorporate integral flanges on one face and clip-on beads on the other face, or may have clip-on beads on both faces.
- g) The method of 'clipping' the beads in place has been previously tested and/or assessed for 30 minute fire resisting applications in accordance with EN1364-1, with a similar glass, i.e. glass of similar construction, weight and pane size to ensure the retention capability of the clips.
- h) The beads may be screw fixed into position but it is not required to screw fix the glazing beads.
- i) The beads are hollow rectangular sections formed from steel at least 1.5mm thick with minimum dimensions of 20mm high by 20mm wide.
- j) The Contraflam Lite 30 fire resisting glass panes are glazed using 'Kerafix 2000' or 'Fiberfrax', or alternative forms of ceramic fibre tape, with dimensions 20 x 5mm. The tape is compressed to 3mm thick or less during glazing.
- k) During glazing the glass shall be carefully handled to avoid scratching or 'shelling' of the glass edge as this may render the glass to be non-fire resisting.
- l) Self-adhesive graphite based intumescent strips are installed to seal the gap between the glass panes and the framing sections. Similar intumescent strips are adhered to the steel sections within the glazing pocket.

- m) Each pane of glass should be set on non-combustible setting blocks.
- n) The maximum height of the glazed screen is 4000mm
- o) There is no maximum width of the glazed screen, provided sufficient expansion allowance is incorporated within the construction.
- p) The top and bottom perimeter framing members are fixed back to a supporting construction of brickwork or masonry at centres not exceeding 600mm. Fixing of the vertical perimeter frame members is optional.
- q) In order to prevent ingress of water a fire rated glazing sealant can be applied to the glazing bead/glass and integrated frame flange/glass interfaces in order to seal the glazing pocket.
- r) All sealants shall have existing test and/or assessment evidence to support its use for 30 minute fire resisting applications in accordance with EN1364-1, with another insulating glass of similar composition.

### **3. TEST EVIDENCE**

Test evidence is available to support the use of Contraflam Lite 30 glass panes for 30 minutes fire resistance in accordance with EN1364-1 and this is summarised in Sections 3.1, 3.2 and 3.3 below.

#### **3.1 Test 2007-Efectis-R0861**

This test was performed at the Efectis Fire Research Centre in Rijswijk, The Netherlands on 19 May 2006. The test specimen was a glazed window frame, constructed out of steel sheet and calcium silicate boards, containing a Contraflam Lite Double glazed unit.

The window frame was constructed from:

- A rectangular steel hollow section 35 x 20 x 2mm
- Steel glazing beads 4 x 45mm
- Calcium silicate (Promatect-H) lining 15 x 45mm

The window frame was fixed to the supporting construction at the top, bottom and at one vertical edge using 10mm diameter and 100mm long steel screws. The other vertical edge was left free from the test frame in order to allow deflection. The gap around the perimeter of the window frame was filled with mineral rockfibre.

The glass pane with dimensions 1500mm wide x 3000mm high was 28.76mm thick.



The glass pane was constructed as follows:

- 4mm float glass (exposed side)
- 8mm spacer
- 5mm tempered glass
- 3mm interlayer
- 44.2mm laminated glass (unexposed side)

The glass pane was positioned on Flammi setting blocks with dimensions 5 x 28 x 80mm. The glazing material was Kerafix Ceramic paper, dimensions 20 x 4mm.

Additional materials were adhered to the unexposed face of the Contraflam Lite glass pane. The aim was to check whether these materials would have an influence on the integrity performance. The following materials were applied:

- 3M: Scotchshield SH4CLARL
- 3M: Scotchtint RE35AMARL
- 3M: FASARA 20PL
- 3M: Scotchcal 100-10 white
- timber, species pine, glued using 2 strips of double sided adhesive tape VITO 125 SS-75.

The glazed window frame was built in a supporting construction of 150mm thick light-weight aerated concrete blocks. The light weight concrete block wall contained an aperture with dimensions 1600mm wide x 3100mm high. The density of the aerated concrete blocks was 625kg/m<sup>3</sup>.

The glazed window frame was tested to EN 1364-1 and satisfied the criteria of the standard as follows:

|                   |          |  |
|-------------------|----------|--|
| <b>Integrity</b>  | <b>:</b> | <b>36 minutes *)</b>                   |
| <b>Insulation</b> | <b>:</b> | <b>36 minutes *)</b>                   |
| <b>Radiation</b>  | <b>:</b> | <b>15kW/m<sup>2</sup> not reached.</b> |

*\*) The criterion was still satisfied after a heating time of 36 minutes.*

The test demonstrated that none of the additional materials prevented the glass achieving 36 minutes integrity, insulation and radiation performance (to 15kW/m<sup>2</sup>).

### **3.2 Test IFCI/577**

This test was performed in the laboratory of IFTS International Fire Testing + Services, Berne, Switzerland on 23 April 2007. The test specimen was a non-loadbearing glazed screen constructed using Contraflam Lite double glazed units in a Jansen Economy 60 steel framing system. The test was performed on a glazed screen with overall dimensions 2950mm wide by 3610mm high. The screen contained three apertures.

The framing sections were Jansen Economy 60, steel tubular hollow sections 50 x 60 x 1.75mm, Art.Nr. 01.684Z, with a 20mm high steel lip.

All panels of the screen were glazed with Contraflam Lite fire resistant double glazed units. The double glazed units were built as follows:

- Planilux 6mm (exposed side)
- Void, filled with air, 10mm wide/Aluminium spacer
- Tempered glass ESG, thickness 6mm
- Gel layer, thickness 3mm
- Tempered glass ESG, thickness 6mm (unexposed side).

The dimensions of the glass panes were as follows:

- 980mm wide x 940mm high
- 980mm wide x 2500mm high
- 1800mm wide x 3500mm high

The glass panes were retained with steel clip-on glazing beads, Jansen 15 x 20 x 1.25mm, Art.Nr. 402.115Z. The glass panes were positioned on "Flammi 12" calcium silicate setting blocks, with dimensions 5 x 31 x 80mm, positioned at between 100mm to 120mm from the corners.

The glass panes were provided with an aluminium separator profile, 10mm wide, around the perimeter. The sheets of glass were adhered to the aluminium separator profile using butyl adhesive. The gel layer in the Contraflam Lite glass panes was sealed around the edges by means of a TPS-sealing strip. The glass pane edges were sealed with a two component poly-sulphite.

The glass panes were sealed using "Kerafix 2000", ceramic fibre glazing tape, manufactured by Gluske, Germany, with dimensions 20 x 5mm.

The glazing beads were fixed by clipping onto steel screws, type Jansen Art.No. 450.007. The screws were positioned at 200 - 300mm between centres and at 48mm from the steel lip. Self adhesive intumescent strips were installed to seal the gap between the glass panes and the steel framing sections. The intumescent strips were of type "Flexpan 200", Art. Nr. 402294, and were adhered to the steel sections in the glazing pocket. The intumescent strips were applied facing the perimeter of the glass panes, interrupted only at the glass setting blocks. The dimensions of the "Flexpan 200" intumescent strips were 31 x 1mm.

The fire resistance of the glazed screen was determined in accordance with EN 1364-1:1999 "Fire resistance tests for non-load bearing elements – Part 1: Walls". The test specimen satisfied the criteria of the standard as follows:

|                   |          |                                   |
|-------------------|----------|-----------------------------------|
| <b>Integrity</b>  | <b>:</b> | <b>36 minutes</b> <sup>*)</sup>   |
| <b>Insulation</b> | <b>:</b> | <b>9 minutes</b> <sup>**)</sup>   |
| <b>Radiation</b>  | <b>:</b> | <b>36 minutes</b> <sup>***)</sup> |

\*) *The integrity criteria were still satisfied after a heating time of 36 minutes.*

\*\*) *The maximum allowed temperature rise of 180°C was exceeded at TC 23 on a framing member after a heating time of 9 minutes. The maximum allowed average temperature rise of 140°C was exceeded on the glass panes after a heating time of 28 minutes.*

\*\*\*) *The heat flux measured at 1 m distance from the centre of the test specimen after 30 minutes was less than 15kW/m<sup>2</sup>.*

### 3.3 Test IFCI/544

This test was performed in the IFTS Laboratory in Berne, Switzerland, on the 7<sup>th</sup> February 2006. The test specimen was a non-loadbearing glazed screen with Contraflam Lite fire resistant double glazed units in a Jansen Economy 60 steel partition.

The glazed screen had overall dimensions 2950mm wide by 3910mm high and contained three apertures. The dimensions of the panes in the apertures were:

- Pane 1a: 480mm wide x 3000mm high
- Pane 1b: 480mm wide x 740mm high
- Pane 1c: 2300mm wide x 3800mm high

The glass panel in Pane 1c was built as follows:

- 6mm float glass (exposed side)
- 10mm aluminium spacer
- 8mm tempered glass
- 3mm interlayer
- 8mm tempered glass (unexposed side)

The ESG tempered glass panes of Panea 1a and 1b were 5mm thick. The glass panes were provided with an aluminium separator profile, 10mm wide, around the perimeter. The sheets of glass were adhered to the aluminium separator profile using butyl adhesive. The gel layer in the Contraflam Lite glass panes was sealed around the edges by means of a TPS-sealing strip. The glass pane edges were sealed with a two component poly-sulphite. The beading, setting block and glass pane sizes were designed to provide a nominal 15mm edge cover. The glass panes were sealed using "Kerafix 2000" ceramic fibre glazing tape, manufactured by Gluske, Germany. The following ceramic tape sizes were applied:

- 20 x 4mm adhered to the steel lip of the hollow tubular steel sections,
- 20 x 3mm adhered to the glazing beads.

Self adhesive intumescent strips were installed to seal the gap between the glass panes and the steel framing sections. The intumescent strips were 'Flexpan 200' and were adhered to the steel sections in the glazing pocket. The intumescent strips were applied around the perimeter of the glass panes, interrupted only at the glass setting blocks. The dimensions of the "Flexpan 200" intumescent strips were as follows:

- 1 x 28mm around panes 1a and 1b,
- 1 x 35mm around pane 1c.

The screen was constructed from Jansen Economy 60 steel tubular hollow sections 50 x 60 x 1.75mm, Art.Nr. 01.684Z, with a 20mm high steel lip. The glazing beads were Jansen 20 x 20 x 1.25mm, type clip-on, Art.Nr. 402.120Z for panes 1a and 1b. Steel glazing bead Jansen 15 x 20 x 1.25mm, type clip-on, Art.Nr. 402.115Z for pane 1c.

The fire test was performed in accordance with EN 1364-1:1999 "Fire resistance tests for non-load bearing elements – Part 1: Walls" and satisfied the criteria of the standard as follows:

**Integrity** : **36 minutes**<sup>\*)</sup>  
**Insulation** : **10 minutes**<sup>\*\*)</sup>  
**Radiation** : **36 minutes**<sup>\*\*\*)</sup>

- \*) *The integrity criteria of the standard were still satisfied after a heating time of 36 minutes.*
- \*\*\*) *The maximum allowed temperature rise of 180°C was exceeded at the head of the frame and at the transom after a heating time of 10 minutes.*
- \*\*\*) *The heat flux measured at 1 m distance from the centre of the test specimen after 30 minutes was less than 15kW/m<sup>2</sup>.*

### **3.4 Test WFRC No. 134116**

This test was performed in the laboratory of Warrington Fire research Centre, UK, on 27 October 2003. The test specimen was an insulated glazed screen assembly with overall dimensions 3020mm wide x 3005mm high. The test specimen comprised a stainless steel profile frame. The frame incorporated a full height mullion and a single transom member such that three apertures were formed. Each aperture was glazed with a unit of Contraflam Lite CFL-60N2 ISO glass nominally 34mm thick. The glass panes were retained within the frame by screw fixed mild steel pressure plates on the unexposed face. The largest unit was of overall dimensions 1630mm wide x 2940mm high.

The mullions and transoms were made of rectangular hollow section mild steel tubes, thickness 2mm, dimensions 140mm x 50mm. The glass panes consisted of the following layers:

- 6mm tempered glass (exposed side)
- 4mm interlayer
- 6mm tempered glass
- 12mm argon filled cavity
- 6mm clear tempered glass (unexposed side)

The dimensions of the glass panes were:

Pane A: 1300mm x 885mm  
Pane B: 1300mm x 2030mm  
Pane C: 1630mm x 2940mm

A Kerafix Ceramic fibre tape was installed around the perimeter of the glass panes. The dimensions of the ceramic fibre tape were 20mm x 6mm, compressed to 3mm.

A Flexpan 200 intumescent seal, size 34mm x 2mm was fixed around the perimeter edge of each glass pane. The intumescent strip was adhered to the framing sections.

The glass panes were held in position by means of mild steel profile sections, thickness 1.5mm, dimensions 45mm x 10mm, with stud fixings through 50mm long slotted holes. Brushed aluminium channels were installed as frame cappings, thickness 1.5mm.

The assembly was fixed into an aperture within a refractory concrete lined, steel restraint frame, such that it incorporated two vertical free edges. The glass units were installed with the 16mm fire resistant glass layer facing the heating conditions of the test.

The fire resistance of the asymmetrical, insulated glazed screen assembly was determined in accordance with EN 1364-1:1999. The test specimen satisfied the criteria of the standard as follows:

**Integrity** : **In excess of 30 minutes**  
**Insulation** : **21 minutes**

## **4. ANALYSIS**

Evaluation of the fire resistance of the proposed Contraflam Lite 30 fire resisting glass panes of various compositions installed in uninsulated metal frames will address the factors that influence the overall fire resistance performance of insulated gel filled fire resisting glass panes under the fire test conditions of EN 1364-1. These include the following:

- Thickness of the glass pane on the unexposed side
- Interlayer thickness
- Glass pane area
- Glass pane height
- Glass pane width
- Single panes and incorporated into IGU's

All assemblies will be assessed in respect to the integrity and radiation criteria of EN 1364-1 for 30 minutes.

### **4.1 The technology of insulated glasses**

The Contraflam Lite 30 glass is a sandwich construction. From the test reports it can be seen that the initially exposed glass pane detaches from the gel layer and cracks quickly after the heating commences. The exposed glass pane then falls away and the gel layer is fully exposed to the heating. The gel layer insulates the pane on the unexposed side of the glazing and provides resistance against heat transfer. The thicker the gel layer is, the longer the pane on the unexposed side will be protected from the heat.

## 4.2 The influence of the interlayer thickness

The interlayer is adhered to the unexposed glass pane. After the exposed glass pane has fallen away the interlayer is slowly degraded by the fire and the thicker the interlayer, the longer it takes before the unexposed glass pane is affected by the heat.

For this reason the thickness of the interlayer is of great importance with respect to protection of the unexposed glass sheet. It can be expected that the thicker the interlayer is the longer the fire duration can be before the glass pane on the unexposed side is affected and therefore:

- a thick interlayer will allow large pane dimensions
- a thick interlayer will contribute to the integrity performance for great fire durations, i.e. longer fire resistance times.

## 4.3 The influence of the glass thickness

The thicker the glass pane is on the unexposed side then the stronger the pane will be during a fire. Thick glass panes take longer time before they start to slump. Assuming they do not crack or fracture it may also be assumed that the thicker the glass pane on the unexposed side, the greater the pane dimensions may be. The fire tests have demonstrated that:

- a thick glass pane on the unexposed side will allow larger pane dimensions
- a thick glass pane on the unexposed side will contribute to the integrity performance for longer fire durations, i.e. greater fire resistance times.

## 4.4 Overview of test evidence

An overview of the test evidence is presented in Table 1 in Appendix A. Table 1 shows Contraflam Lite 30 glass panes with glass pane thicknesses varying from 13mm to 19mm. During fire conditions the remaining components of the pane are the interlayer and the glass pane on the unexposed side, i.e. the working glass-build-up during a fire.

Three glass panes can be identified in Table 1 with a large glass pane area. These panes are:

- 16mm total thickness, 1500mm wide, 3000mm high, area 4.5m<sup>2</sup>, glass build-up laminated 44.2-3-5 IGU, working glass-build-up during fire laminated 44.2-3 (2007-Efectis-R0861)
- 15mm total thickness, 1800mm wide, 3500mm high, area 6.3m<sup>2</sup>, glass build-up 6-3-6 IGU, working glass-build-up during fire 6-3 (IFCI/577)
- 19mm total thickness, 2300mm wide, 3800mm high, area 8.74m<sup>2</sup>, glass build-up 8-3-8 IGU, working glass-build-up during fire 8-3 (IFCI/544)

## **4.5 Integrity performance of the glass panes**

### Contraflam Lite 5-3-5

The 13mm Contraflam Lite 5-3-5 glass panes were tested in IFCI/544. This test has demonstrated that a Contraflam Lite 5-3-5 glass pane can satisfy the integrity criteria of EN 1364-1 for at least 36 minutes. The height of the largest glass pane was 3000mm and after a heating time of 36 minutes the interlayer was still present to protect the remaining glass pane on the unexposed side. The observations were terminated on request of the sponsor and after 36 minutes heating time the integrity criteria were still satisfied.

### Contraflam Lite 6-3-6

The 15mm Contraflam Lite 6-3-6 glass panes were tested in IFCI/577. This test has demonstrated that a Contraflam Lite 6-3-6 glass pane with dimensions 1800mm wide x 3500mm high can satisfy the integrity criteria of EN 1364-1 for at least 36 minutes. After a heating time of 36 minutes the interlayer was still present to protect the remaining glass pane on the unexposed side. The observations were terminated on request of the sponsor and after 36 minutes heating time the integrity criteria were still satisfied.

### Contraflam Lite 8-3-8

The 19mm Contraflam Lite 8-3-8 glass pane was tested in IFCI/544. This test has demonstrated that a Contraflam Lite 8-3-8 glass pane with dimensions 2300mm wide by 3800mm high can satisfy the integrity criteria of EN 1364-1 for at least 36 minutes. After a heating time of 36 minutes the interlayer was still present to protect the remaining glass pane on the unexposed side. The observations were terminated on request of the sponsor and after 36 minutes heating time the integrity criteria were still satisfied.

The proposed glass panes all have an interlayer with a thickness of 3mm. The fire tests have demonstrated that proposed glass panes with an interlayer thickness of 3mm will satisfy the integrity criteria for at least 36 minutes.

## **4.6 Radiation performance**

### **4.6.1 General**

The Dutch Standard NEN 6069: 2005 prescribes that the "thermal insulation with respect to radiation" requirement should be satisfied. This requirement is applicable for the whole construction and it means that the heat flux measured at 1m distance from the centre of the glazed construction should not exceed 15kW/m<sup>2</sup> for the full fire resistance period.

This means that the height and the width of the construction are restricted. In order to obtain the maximum allowed overall dimensions of the glazed construction, a calculation on the radiative characteristics of the glazed elements has been carried out.

The aim of the calculations is to determine the maximum height and width for glazed constructions using Contraflam Lite 30 glass panes, in order to satisfy the radiation criterion of 15kW/m<sup>2</sup> as stated in the Dutch standard NEN6069: 2005.

The heat flux radiated by glazed screens is dependent upon its dimensions. The greater the dimensions the higher the heat flux.

The heat flux from glazed constructions using Contraflam Lite 30 glass panes has been calculated for various dimensions.

The height and the width were each assumed to be in a range from 0.00m to 30.00m.

For each of the combinations of height and width the heat flux was calculated at 1m distance from the centre point of the glazed construction.

The calculations were based on Stefan Boltzmann's law:

$$Q = \varepsilon F \sigma T^4$$

Where:

|               |   |  |
|---------------|---|--|
| Q             | = | heat flux [kW/m <sup>2</sup> ]                                   |
| $\varepsilon$ | = | emissivity [-]   |
| F             | = | configuration factor [-]   |
| $\sigma$      | = | Stefan Boltzmann's constant [W/(m <sup>2</sup> K <sup>4</sup> )] |
| T             | = | surface temperature of the glass [K]                             |

Further, the heat flux of glazed constructions has been calculated at intervals of 0.01m to vary the height and the width.

It is noted that the calculation results can only be used to check compliance with the radiation requirement. Information about the behaviour of the glass panes with respect to integrity is outside the scope of this radiative heat transfer calculation and therefore the curve cannot be applied in order to check integrity performance.

In the calculation it is presumed that the perimeter framing including mullions and transoms are non-insulating and will therefore make a difference to the heat flux. The surface temperature of the steel sections is generally higher than the surface temperature of the glazing. Taking into account the outside dimensions of the steel perimeter framing, and the surface area taken by transoms and mullions, will therefore provide heat flux results which are conservative.

#### **4.6.2 Contraflam Lite 30**

In order to characterise the thermal behaviour of Contraflam Lite 30, the following test evidence has been used from the test performed at the Efectis Centre for Fire Research, Rijswijk, The Netherlands and from the tests performed at the IFT+S Fire Laboratory, Berne, Switzerland.



Test report: 2007-Efectis-R0861

Test date: 19 May 2006

Dimensions of the test specimen: 3050mm high x 1550mm wide

Mean surface temperature of the Contraflam Lite 30 glass pane after 30 minutes: 98°C

Measured heat flux at 1m distance after 30 minutes: 0.6 kW/m<sup>2</sup>.

Configuration factor F of the test specimen: 0.556432

Using Stefan Boltzmann's law the emissivity of the Contraflam Lite 30 glass pane after 30 minutes heating time can be calculated. The emissivity  $\varepsilon$  is 1.00 [dimensionless].

Test report: IFCI/577

Test date: 23 April 2007

Dimensions of the test specimen: 3610mm high x 2950mm wide

Mean surface temperature of the Contraflam Lite 30 glass pane after 30 minutes: 186°C

Measured heat flux at 1m distance after 30 minutes: 3.5 kW/m<sup>2</sup>

Configuration factor F of the test specimen: 0.762818

Using Stefan Boltzmann's law the emissivity of the Contraflam Lite 30 glass pane after 30 minutes heating time can be calculated. The emissivity  $\varepsilon$  is 1.00 [dimensionless].

Test report: IFCI/544

Test date: 7 February 2006

Dimensions of the test specimen: 3910mm high x 2950mm wide

Mean surface temperature of the Contraflam Lite 30 glass pane after 30 minutes: 178°C

Measured heat flux at 1m distance after 30 minutes: 1.8 kW/m<sup>2</sup>.

Configuration factor F of the test specimen: 0.773464

Using Stefan Boltzmann's law the emissivity of the Contraflam Lite 30 glass pane after 30 minutes heating time can be calculated. The emissivity  $\varepsilon$  is 1.00 [dimensionless].

## Graphical presentation

Combinations of height and width of the overall construction which comply with the heat flux criterion of 15kW/m<sup>2</sup> after 30 minutes are shown in **Figure 08016/06** in Appendix B. **Figure 08016/06** shows that even up to 30m x 30m the criterion of 15kW/m<sup>2</sup> is still not exceeded. Although it looks like the graphically derived curve is missing in **Figure 08016/06**, the correct interpretation is that this graph shows that all combinations of height and width comply with the radiation criterion.

### **4.7 Construction of the envelopes of maximum pane sizes**

In the fire tests performed, a range of different pane sizes were tested. The test reports have demonstrated that Contraflam Lite 30 glass does not slump and does not soften at high temperature. Contraflam Lite 30 glass does not require a method of glazing which applies any significant clamping action or which bonds the glass within the glazing pocket, because it does not slump.

The glass pane on the non-exposed side stayed intact as it was well protected by the interlayer. When the interlayer detaches from the outer glass, integrity failure will soon occur, due to temperature differences on the surface causing cracking.

As the Contraflam Lite 30 glass is not slumping because of the protection to the outer layer of glass by the interlayer, the fire resistance is related to the thickness of the gel layer. The gel layer creates an insulating char which can be seen when viewed from the exposed side during heating. The char decreases in thickness during heating and therefore the longer the heating time, the thicker the gel layer needs to be in order to provide sufficient protection.

From the dimensions of the Contraflam Lite 30 glazing tested, it follows that no great differences exist between the performances of large and small panes with the same gel thickness.

The method of failure is related to the erosion of the gel layer. If the gel layer is reduced in thickness the pane on the unexposed side becomes affected. When the glass pane is directly exposed to heating from the furnace, the pane suddenly cracks due to unequal glass temperature causing excessively high glass stresses, as differential expansion is localised. Hence the fire performance of the Contraflam Lite 30 glass is, in our opinion, shown by analysis to be related to the performance of the gel layer.

For this reason the envelope of approved glass dimensions is symmetrical in that the maximum height and associated width are the inverse figures of the maximum width and associated height.

The requirement in this Field of Application report is that the glass sizes are within an envelope as follows:

13mm Contraflam Lite (5-3-5): see **Figure IFCA/08016/07**

15mm Contraflam Lite (6-3-6): see **Figure IFCA/08016/08**

19mm Contraflam Lite (8-3-8): see **Figure IFCA/08016/09**

## 4.8 Direction of exposure

### 4.8.1 Glazing beads

The glazing beads tested in 2007-Efectis-R0861, IFCI/577 and IFCI/544 were installed on the fire exposed side. This is the most onerous configuration, as steel glazing beads tend to expand and distort out of the frame rebate. Therefore, it is the opinion of IFC that the glazing beads may also be installed on the unexposed side.

### 4.8.2 Secondary float glass incorporated in IGU's

#### Float glass on fire exposed side

Tests 2007-Efectis-R0861, IFCI/577 and IFCI/544 have demonstrated that the float glass shatters and falls away within 3 minutes. From this time the Contraflam Lite 30 glass panes are exposed to fire conditions as if they were a single pane.

## 4.9 Insulating Double Glazed Units (IGU's) versus single Contraflam Lite 30 glazing

Contraflam Lite 30 Insulating Double Glazed Units were tested in 2007-Efectis-R0861, IFCI/577 and in IFCI/544 with float glass sheet on the exposed side.

The float glass sheets shattered after 3 minutes heating time and fell into the furnace. After this time the fire resisting Contraflam Lite 30 glass pane was fully exposed to the standard fire conditions. Hence after a heating time of 3 minutes the remaining glass pane was a single Contraflam Lite 30 glass pane, the only difference being the glazing pocket design. At the moment when the float glass shatters and falls into the furnace there are still some glass parts remaining in the glazing pocket which were sections to the float glass pane. This is illustrated in **Figure 08016/10**. These glass particles are wedged in between the two Kerafix 2000 ceramic fibre strips and remain in position as long as the aluminium distance/separating profile around the perimeter of the glass pane is still intact and capable of resisting the wedging force.

After a heating time of approximately 10 minutes the aluminium separating profile gets hot and starts to lose its strength and stiffness. It is also at this time that the "Flexpan 200" intumescent strip, which is adhered to the glazing pocket, starts to activate. The intumescent strip closes the gap between the edges of the Contraflam Lite 30 glass pane and the steel framing sections. Therefore, the remaining glass sections and the aluminium separating profile are no longer necessary to seal the gap at the glazing pocket. The "Flexpan 200" intumescent strip effectively takes over the retention of the glass.

There is another event that happens. The gel layer starts to build steam on the exposed side. The Contraflam Lite 30 glass is a sandwich construction, from tests 2007-Efectis-R0861, IFCI/577 and IFCI/544 it can be seen that the exposed glass pane detaches from the gel layer and cracks quickly after it is exposed directly to the heating. The exposed tempered glass pane falls away and the gel layer insulates the pane on the unexposed side of the glazing and provides resistance against heat transfer. The thicker the gel layer is, the longer the pane on the unexposed side will be protected against the heat. During the test IFCI/577 the exposed tempered glass pane shattered and fell into the furnace after 10 minutes. Hence at this time, the gel layer was fully exposed to the standard time temperature curve.

This phenomenon is identical for IGU and single pane Contraflam Lite 30, and is illustrated in **Figure 08013/10** and **11**.

In view of the above rationale there is no difference between the single panel and the IGU Contraflam Lite 30, as:

- (1) the sealing of the perimeter of the remaining tempered glass pane on the unexposed side is in both cases provided by the "Flexpan 200" intumescent strip.
- (2) the tempered glass pane on the unexposed side is in both cases protected by the gel layer in an identical way, and
- (3) the temperature development in the unexposed tempered glass pane is identical for both cases and therefore the ultimate mode of failure of the unexposed glass layer, i.e. slumping of the glass pane, will occur after the same heating time both for the single and the IGU Contraflam Lite 30 glass panes. This slumping of the glass was however not experienced, as the heating was terminated on request of the sponsor before the unexposed glass pane temperature was high enough to cause slumping.

It is the opinion of IFC that if the single Contraflam Lite 30 glass pane would be tested to the EN 1364-1 test standard the results of the fire test would be identical or better than as achieved in tests 2007-Efectis-R0861, IFCI/577 and IFCI/544.

#### **4.10 Longitudinal thermal expansion**

Longitudinal thermal expansion will occur in all horizontal and vertical framing members. If such expansion cannot be accommodated, there is potential for considerable lateral deflection.

At the head and cill, the deflection would be physically limited by the fixings to the supporting structure, although excessive expansion/movement would still induce detrimental stresses. More critical areas are any transoms and/or intermediate rails, the unrestricted expansion of which would exacerbate lateral deflection of the adjacent mullions.

Allowance must be included to accept the longitudinal expansion. An example of a fixing detail to accommodate the appropriate levels is shown in **Figure 08016/12**. Allowances (see dimension X in **Figure 08016/12**) are as follows:

- at least 15mm for 3m widths,
- at least 31mm for 4m widths,
- at least 47mm for 5m widths,
- and at least 63mm for 6m widths.

The total allowance may be included at one end of the assembly, or divided between the two ends, as preferred, but only in assemblies where the total length does not exceed 6 metres. Where the length is greater, additional allowance must be included between mullions every 6 metres (or less to suit module or pane widths) to ensure that the cumulative expansion can be safely accommodated along the entire screen length.

The mid-joint should be made by applying a steel strip with dimensions 80mm wide by 3mm thick on both sides on the vertical framing member at the joint. The steel strips should be spot welded to the framing member, by means of tack welds, length 20mm, at 200mm centres. By applying the two steel strips a groove is formed, in order to receive the adjacent vertical framing member. The groove should be filled with mineral rock fibre. The steel strips (cover plates) at the sliding joint will follow the expansion and thermal bow of the vertical frame member. As such the cover strips will not cause any expansion problems when they are long and continuous.

On the basis of this analysis, this Field of Application Report approves screen assemblies of unrestricted overall width, provided that all the requirements of this Report have been complied with.

#### **4.11 Films applied to the free vision area of Contraflam Lite 30 glass panes**

The films may consist of adhesive/adherent polyester/polyethylene terephthalat (PET) or polyvinyl chloride (PVC). These films may be applied to the free vision area of a Contraflam Lite 30 glazed element. The thickness of the film is within 25µm and 250µm.

##### Film applied to exposed face

If the film is applied to the exposed face of the glass pane, the film is directly exposed to the flames and will burn off, i.e. the film will fall off together with the exposed glass pane. Tests IFCI/577 and IFCI/544 have demonstrated that the exposed glass pane falls down after a heating time of approximately 3 minutes. This does not have any negative influence on the fire resistance performance of the Contraflam Lite 30 glass. Therefore IFC is of the opinion that adhesive/adherent polyester/polyethylene terephthalat (PET) or polyvinyl chloride (PVC) films may be applied to the exposed face of the Contraflam Lite 30 glass panes.

#### Film applied to unexposed face

If the film is applied to the unexposed glass face then the film will be gradually heated as a function of the heating time. Initially the film discolours then the film starts to produce some smoke. The surface temperature of the unexposed face of the glass after a heating time of 30 minutes is approximately 186°C. The radiation and conduction from a glass surface with a temperature of 186°C is not sufficiently high to cause ignition of the film. The film will detach from the unexposed glass pane and will fall down. During test 2007-Efectis-R0861 additional materials were adhered to the unexposed face of the Contraflam Lite glass pane. The aim was to check whether these materials would have an influence on the integrity performance. The following materials were applied:

- 3M: Scotchshield SH4CLARL
- 3M: Scotchtint RE35AMARL
- 3M: FASARA 20PL
- 3M: Scotchcal 100-10 white
- timber, species pine, glued using 2 strips of double sided adhesive tape VITO 125 SS-75.

Test 2007-Efectis-R0861 has demonstrated that none of the additional materials had an adverse influence on the integrity performance of the glass pane. IFC have witnessed many fire tests with insulated glass panes containing a gel interlayer, which were provided with a film to the unexposed side, and none of these tests demonstrated a premature integrity failure or an adverse influence on the integrity performance by the film applied to the glass pane. Therefore IFC is of the opinion that adhesive/adherent polyester/polyethylene terephthalat (PET) or polyvinyl chloride (PVC) films may be applied to the unexposed face of the Contraflam Lite 30 glass panes.

#### Laminated safety glass

Laminated safety glass contains a PVB (polyvinylbutyral) layer. Laminated safety glass with a thickness  $\geq 8\text{mm}$  is allowed for application in Contraflam Lite 30 for 30 minutes integrity performance. Test 2007-Efectis-R0861 has demonstrated that the PVB layer in laminated safety glass does not ignite up to a heating time of 36 minutes, if the laminated safety glass is installed on the unexposed side.

If the laminated safety glass is installed on the fire exposed side this will have no influence on the integrity performance.

## **5. CONCLUSION**

It is the opinion of International Fire Consultants Ltd that, if the proposed Contraflam Lite 30 glass panes with various compositions, dimensions and aspect ratio's to be installed in uninsulated steel screens were manufactured and installed in accordance with the requirements of this Field of Application Report, and tested for fire resistance, the Contraflam Lite 30 glass panes would satisfy the integrity criteria and radiation criterion of  $15\text{kW/m}^2$  of EN 1364-1 for the proposed period of 30 minutes.

The conclusion applies to glass/window frame structures that are constructed in accordance with this Field of Application:

- with glazing height and width measurements not greater than the envelope of approved pane sizes (see **Figures IFCA/08016/07 to 09** in Appendix B).
- built-in screens as specified in Section 2.2;
- with glazing thicknesses as specified in Section 2.1;
- built-in as specified, including the sealing, in masonry walls with a thickness and a mass per unit volume of at least 150mm and 650kg/m<sup>3</sup> respectively or in concrete walls with a thickness of at least 100mm.

## 6. LIMITATIONS

This Field of Application Report, which is only valid for the Contraflam Lite 30 glass panes installed in uninsulated steel framed screens, addresses itself solely to the ability of the assemblies described to satisfy the criteria of the fire resistance test. It does not imply any suitability for use with respect to other unspecified criteria.

This document only considers the Contraflam Lite 30 glass panes described herein, and assumes that the surrounding construction will provide no less restraint than the tested assembly and that it will remain in place and be substantially intact for the full fire resistance period.

Where the constructional information in this report is taken from details provided to International Fire Consultants Ltd (IFC) and/or from fire resistance test reports referenced herein, it is, therefore, limited to the information given in those documents. It is necessarily dependent upon the accuracy and completeness of that information. Where constructional or manufacturing details are not specified, or discussed herein, it should not, therefore, be taken to infer approval of variation in such details from those tested or otherwise approved.

Where the assessed constructions have not been subject to an on-site audit by International Fire Consultants Ltd, it is the responsibility of anyone using this report to confirm that all aspects of the assemblies fully comply with the descriptions and limitations herein.

Any materials specified in this report have been selected and judged primarily on their fire performance. IFC do not claim expertise in areas other than fire safety. Whilst observing all possible care in the specification of solutions, we would draw the reader's attention to the fact that during the construction and procurement process, the materials used should be subjected to more general examination regarding the wider Health and Safety, and CoSHH Regulations (Control of Substances Hazardous to Health).

## 7. VALIDITY

This Field of Application has been prepared based on International Fire Consultants Ltd's present knowledge of the products described, the stated testing regime and the submitted test evidence. For this reason anyone using this document after May 2013 should confirm its ongoing validity.

Prepared by:



**J C A van de Weijgert**  
**MSc MIFireE MBEng Eur Ing**  
Senior Consultant  
International Fire Consultants Ltd (IFC)

Checked by:



**Peter E Jackman**  
**MIFireE IEng FBEng AIWSc**  
Technical Director  
International Fire Consultants Ltd (IFC)



## **APPENDIX A**

### **Overview Test Evidence**

***The Table in this Appendix is not included  
in the sequential page numbering of this report.***

**EW 30**

| 2007- Efectis - R0861 (36min.) | IFCI/577 (36min.) | IFCI/544 (36min.) | Tested   | Application in assessment                               |
|--------------------------------|-------------------|-------------------|--|---|
| X                              |                   |                   | tested frames: 1x Vetroframe →   | steel frame system with steel lip profiles              |
|                                | X                 | X                 | 2x Jansen Economy 60 →   | e.g. Jansen ECO, Forster Presto                         |
|                                | X                 | X                 | Partition  | Partition   |
|                                |                   | X                 | height of construction: 3910 mm  | <= 4000 mm  |
|                                |                   | X                 | width of construction: 2950 mm., one side free   | endless length  |
| X                              |                   |                   | tested glass: 44.2 / IL.3 / ESG5 / spacer 8 / Fl.4<br>Float 4 on FS has no influence to the test result<br>dimensions: 1500 x 3000 mm  | CFL 30 IGU 1500 x 3000 mm<br>CFL 30 Mono 1500 x 3000 mm |
|                                | X                 |                   | tested glass: ESG6 / IL.3 / ESG6 / spacer 10 / Fl.6<br>Float 6 on FS has no influence to the test result<br>dimensions: 1800 x 3500 mm | CFL 30 IGU 1800 x 3500 mm<br>CFL 30 Mono 1800 x 3500 mm |
|                                |                   | X                 | tested glass: ESG8 / IL.3 / ESG8 / spacer 10 / Fl.6<br>Float 6 on FS has no influence to the test result<br>dimensions: 2300 x 3800 mm | CFL 30 IGU 2300 x 3800 mm<br>CFL 30 Mono 2300 x 3800 mm |
| X                              | X                 | X                 | test result >= 36 min. E+EW  | use for EW 30   |

**Table 1: Overview test evidence**

*Note, Test WFRC No. 134116 is not summarised in this table as its inclusion within this report is to demonstrate performance with float glass on the unexposed side*

## **APPENDIX B**

**Figures IFCA/08016/01 to 12**

***The figures in this Appendix are not included  
in the sequential page numbering of this report.***

### **LEGEND TO FIGURE 08016/10 and 11**

1. ESG glass on unexposed face
2. Gel interlayer directly exposed to the fire
3. Remaining ESG glass on exposed face
4. Steel clip-on glazing bead
5. Uninsulated steel tubular section
6. Ceramic fibre glazing strip
7. Steel clip-on screw for fixing glazing bead
8. Mineral rock fibre
9. Brick, concrete, stone like, supporting construction
10. Planilux float glass, thickness 4mm or 6mm
11. Aluminium spacer profile
12. Intumescent strip Flexpan 200

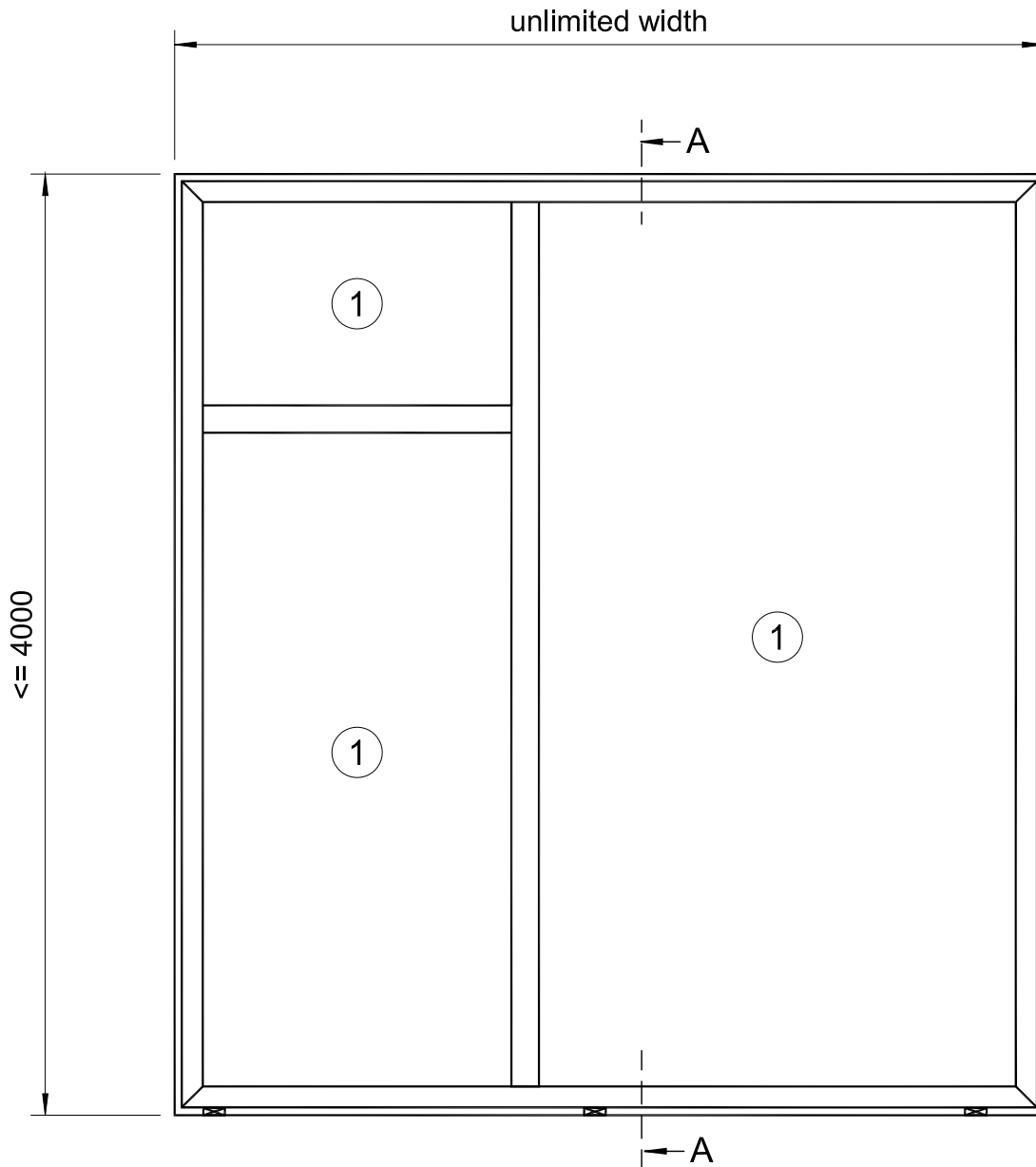

- ① SGG CONTRAFLAM LITE 30  $\geq$  13 mm, and SGG CONTRAFLAM LITE 30 IGU  $\geq$  23 mm, with the maximum dimension 1500 x 3000 mm  
 or  
 SGG CONTRAFLAM LITE 30  $\geq$  15 mm, and SGG CONTRAFLAM LITE 30 IGU  $\geq$  25 mm, with the maximum dimension 1800 x 3500 mm  
 or  
 SGG CONTRAFLAM LITE 30  $\geq$  19 mm, and SGG CONTRAFLAM LITE 30 IGU  $\geq$  29 mm, with the maximum dimension 2300 x 3800 mm.

|   |   |  |
|---|---|--|
| <p>This drawing is Copyright©<br/>         Contractors must check all dimensions.<br/>         Any discrepancies must be reported before<br/>         work proceeds.<br/>         Only work to dimensions stated on drawing.</p>  | <p><b>INTERNATIONAL FIRE CONSULTANTS LTD</b></p> <p>20 Park Street Princes Risborough Buckinghamshire HP27 9AH United Kingdom<br/>         Tel: +44 (0) 1844 275500 Fax: +44 (0) 1844 274002 Email: ifc@intfire.com Website: http://www.intfire.com</p> |  |
| <p>Field of Application Report IFCA/08016<br/>         Vetrotech Saint-Gobain Int. AG<br/>         Contraflam Lite 30 Glass Panes, Single &amp; IGU's,<br/>         with Various Dimensions &amp; Glass Thicknesses for<br/>         30 Minutes Integrity &amp; Radiation Performance</p> | <p>Elevation View of Element</p>  | <p>Job number: 7652<br/>         Drawn by: CSP    Checked by: CM<br/>         Not To Scale    March 2008<br/> <span style="font-size: 1.5em; font-weight: bold;">08016/01</span></p> |

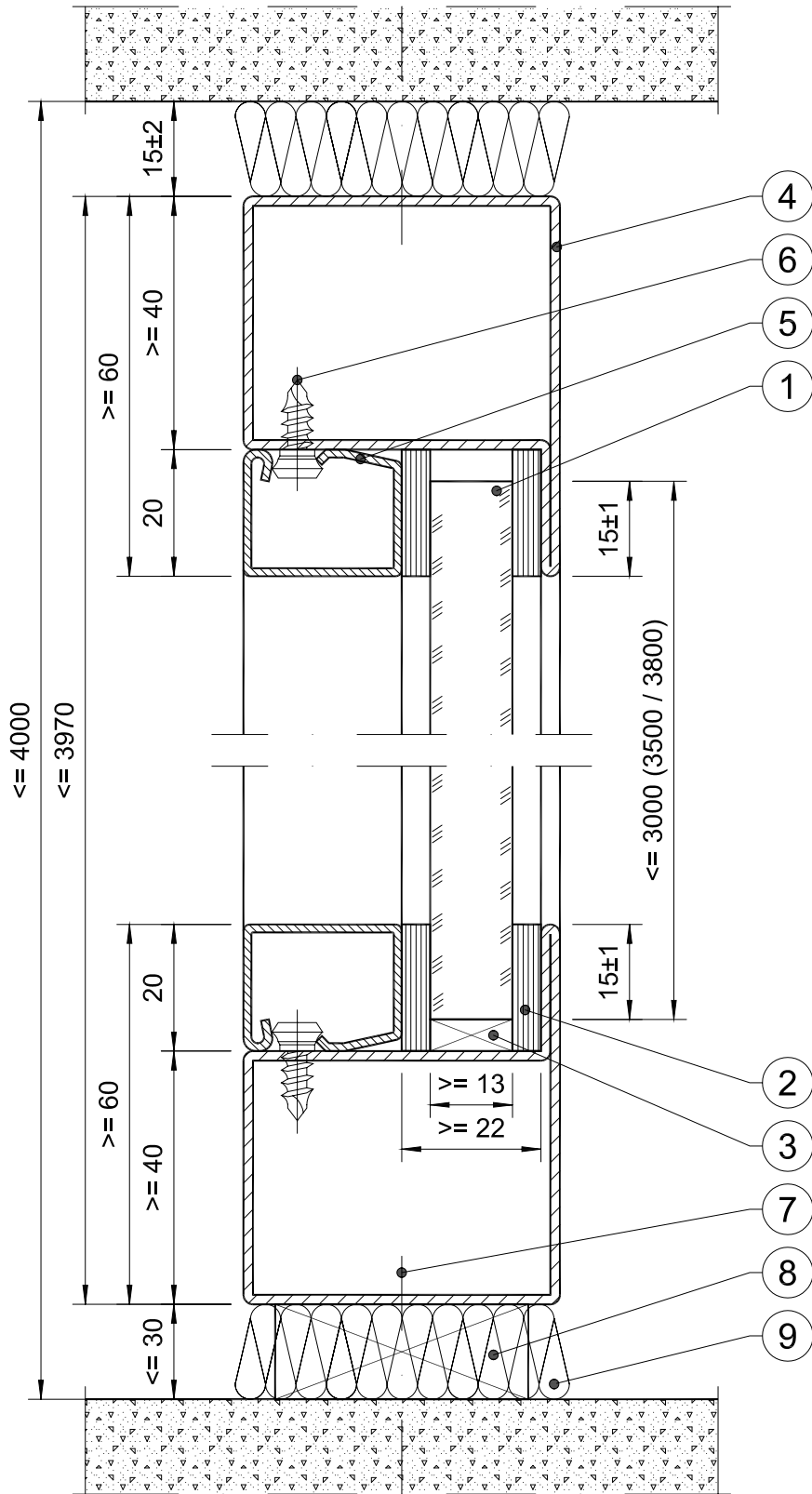

This drawing is Copyright©  
 Contractors must check all dimensions.  
 Any discrepancies must be reported before  
 work proceeds.  
 Only work to dimensions stated on drawing.

**INTERNATIONAL FIRE CONSULTANTS LTD**

20 Park Street Princes Risborough Buckinghamshire HP27 9AH United Kingdom  
 Tel: +44 (0) 1844 275500 Fax: +44 (0) 1844 274002 Email: ifc@intfire.com Website: http://www.intfire.com

Field of Application Report IFCA/08016  
 Vetrotech Saint-Gobain Int. AG  
 Contraflam Lite 30 Glass Panes, Single # IGU's,  
 with Various Dimensions # Glass Thicknesses for  
 30 Minutes Integrity # Radiation Performance

Section A-A

|                  |                |
|------------------|----------------|
| Job number: 7652 |                |
| Drawn by: CSP    | Checked by: CM |
| Not To Scale     | March 2008     |
| 08016/02         |                |

## SPECIMEN COMPONENT SCHEDULE

- 1) "SGG CONTRAFLAM LITE 30"- pane  $\geq$  13 mm, or  
 "SGG CONTRAFLAM LITE 30 IGU"-pane  $\geq$  23 mm,  
 with the max. dimension 1500 x 3000 mm,  
 or  
 "SGG CONTRAFLAM LITE 30"- pane  $\geq$  15 mm, or  
 "SGG CONTRAFLAM LITE 30 IGU"-pane  $\geq$  25 mm,  
 with the max. dimension 1800 x 3500 mm,  
 or  
 "SGG CONTRAFLAM LITE 30"- pane  $\geq$  19 mm, or  
 "SGG CONTRAFLAM LITE 30 IGU"-pane  $\geq$  29 mm,  
 with the max. dimension 2300 x 3800 mm
- 2) Glazing gasket, self adhesive tape, 20 mm wide x 5 mm thick,  
 for example "Gluske: KERAFIX 2000", or similar
- 3) Setting block,  $\geq$  13 mm (glassthickness) x 80 mm long x 5 mm thick,  
 for example "Gluske: FLAMMI", or similar
- 4) Steel lip profile,  $\geq$  50 x 60 x 1,5 mm,  
 for example "Jansen Economy 50, Art.No.: 01.564", or similar
- 5) Steel glazing beads,  $\geq$  12 x 20 x 1,25 mm, suitable to 4),  
 or example "Jansen Art.No.: 402.112Z", or similar
- 6) Beading fixture studs, suitable to 4) & 5)  
 for example "Jansen Art.No.: 450.007, or similar,  
 positioned at  $\leq$  250 mm distance between centres
- 7) Steel anchor bolts  $\geq$  4,5 x 60 mm at  $\leq$  600 mm centres for fixture of frame
- 8) Setting block,  $\geq$  30 mm wide x 80 mm long x 10 mm thick,  
 for example "Gluske: FLAMMI", or similar
- 9) Mineral rockfibre, noncombustible

|  |   |                  |  |               |                |              |            |          |  |
|--|---|------------------|--|---------------|----------------|--------------|------------|----------|--|
| This drawing is Copyright©<br>Contractors must check all dimensions.<br>Any discrepancies must be reported before<br>work proceeds.<br>Only work to dimensions stated on drawing.  | <hr/> <b>INTERNATIONAL FIRE CONSULTANTS LTD</b> <hr/> 20 Park Street Princes Risborough Buckinghamshire HP27 9AH United Kingdom<br>Tel: +44 (0) 1844 275500 Fax: +44 (0) 1844 274002 Email: ifc@intfire.com Website: <a href="http://www.intfire.com">http://www.intfire.com</a>  |                  |  |               |                |              |            |          |  |
| Field of Application Report IFCA/08016<br>Vetrotech Saint-Gobain Int. AG<br>Contraflam Lite 30 Glass Panes, Single & IGU's,<br>with Various Dimensions & Glass Thicknesses for<br>30 Minutes Integrity & Radiation Performance | <div style="text-align: center;">Component Schedule</div> <table border="1" style="width: 100%; border-collapse: collapse; margin-top: 10px;"> <tr> <td colspan="2" style="text-align: center;">Job number: 7652</td> </tr> <tr> <td style="width: 50%;">Drawn by: CSP</td> <td style="width: 50%;">Checked by: CM</td> </tr> <tr> <td style="width: 50%;">Not To Scale</td> <td style="width: 50%;">March 2008</td> </tr> <tr> <td colspan="2" style="text-align: center; font-size: 1.2em; font-weight: bold;">08016/03</td> </tr> </table> | Job number: 7652 |  | Drawn by: CSP | Checked by: CM | Not To Scale | March 2008 | 08016/03 |  |
| Job number: 7652   |   |                  |  |               |                |              |            |          |  |
| Drawn by: CSP  | Checked by: CM  |                  |  |               |                |              |            |          |  |
| Not To Scale   | March 2008  |                  |  |               |                |              |            |          |  |
| 08016/03   |   |                  |  |               |                |              |            |          |  |

## SGG CONTRAFLAM Lite 30

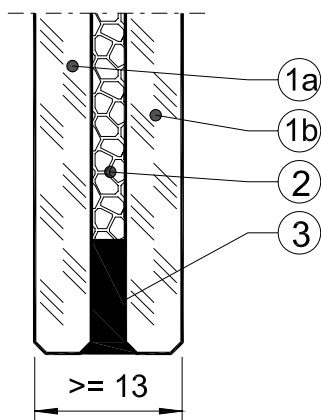

1a/1b) Tempered glass  $\geq 5$  mm thick or  
 Tempered patterned\* glass  $\geq 6$  mm thick or  
 Laminated safety glass  $\geq 8$  mm thick  
 individual panes can be tinted, coated, surface treated  
 (tempered glass acc. to EN 12150 or EN 14179, laminated glass  
 acc. to EN 14449 or EN 12543)

2) Interlayer,  $\geq 3$  mm thick (acc. to VSGI standards)

3) Edge compound (acc. to VSGI standards)

Tolerances are given in standards or CE documents

\*patterned glass types: SGG SR SILVIT, SGG SR ARENA C, SGG MASTER-POINT,  
 SGG MASTER-LIGNE, SGG MASTER-CARRE, SGG MASTER-RAY, SGG MASTER-LENS

Adhesive/ adherent polyester/ polyethylen terephthalat (PET) or polyvinyle chloride (PVC) films may be  
 applied to the free vision area of a glazed element. They may have a thickness between 25 and 250  $\mu\text{m}$ .

|  |   |                  |  |               |                |              |            |          |  |
|--|---|------------------|--|---------------|----------------|--------------|------------|----------|--|
| This drawing is Copyright©<br>Contractors must check all dimensions.<br>Any discrepancies must be reported before<br>work proceeds.<br>Only work to dimensions stated on drawing.  | <hr style="border: 1px solid black;"/> <h3 style="margin: 0;">INTERNATIONAL FIRE CONSULTANTS LTD</h3> <hr style="border: 1px solid black;"/> <p style="margin: 0;">20 Park Street Princes Risborough Buckinghamshire HP27 9AH United Kingdom<br/>                 Tel: +44 (0) 1844 275500 Fax: +44 (0) 1844 274002 Email: ifc@intfire.com Website: <a href="http://www.intfire.com">http://www.intfire.com</a></p> |                  |  |               |                |              |            |          |  |
| Field of Application Report IFCA/08016<br>Vetrotech Saint-Gobain Int. AG<br>Contraflam Lite 30 Glass Panes, Single & IGU's,<br>with Various Dimensions & Glass Thicknesses for<br>30 Minutes Integrity & Radiation Performance   | SGG Contrflam Lite 30<br>Glass Description  |                  |  |               |                |              |            |          |  |
| <table style="width: 100%; border-collapse: collapse;"> <tr> <td colspan="2" style="text-align: right; padding: 2px;">Job number: 7652</td> </tr> <tr> <td style="padding: 2px;">Drawn by: CSP</td> <td style="padding: 2px;">Checked by: CM</td> </tr> <tr> <td style="padding: 2px;">Not To Scale</td> <td style="padding: 2px;">March 2008</td> </tr> <tr> <td colspan="2" style="text-align: center; padding: 5px; font-size: 1.2em;">08016/04</td> </tr> </table> |   | Job number: 7652 |  | Drawn by: CSP | Checked by: CM | Not To Scale | March 2008 | 08016/04 |  |
| Job number: 7652   |   |                  |  |               |                |              |            |          |  |
| Drawn by: CSP  | Checked by: CM  |                  |  |               |                |              |            |          |  |
| Not To Scale   | March 2008  |                  |  |               |                |              |            |          |  |
| 08016/04   |   |                  |  |               |                |              |            |          |  |



# SGG CONTRAFLAM Lite 30 (Insulating glass unit acc. to EN 1279)

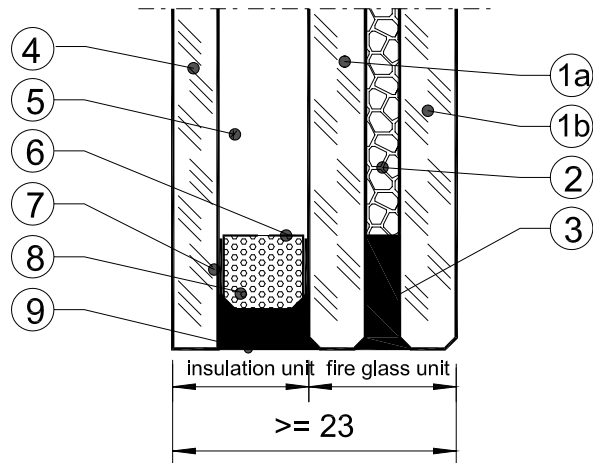

- 1a/1b) Tempered glass  $\geq 5$  mm thick or Tempered patterned\* glass  $\geq 6$  mm thick or Laminated safety glass  $\geq 8$  mm thick individual panes can be tinted, coated, surface treated (tempered glass acc. to EN 12150 or EN 14179, laminated glass acc. to EN 14449 or EN 12543)
- 2) Interlayer,  $\geq 3$  mm thick (acc. to VSGI standards)
- 3) Edge compound (acc. to VSGI standards)
- 4) Glass  $\geq 4$  mm thick of:  
 Float glass (acc. to EN 572)  
 Tempered glass (acc. to EN 12150 or EN 14179)  
 Laminated glass (acc. to EN 14449 or EN 12543)  
 pane can be tinted, coated, patterned, surface treated
- 5) Air or gas filling
- 6) Spacer  $\geq 6$  mm (acc. to VSGI standards)
- 7) Primary sealant (acc. to VSGI standards)
- 8) Desiccant (acc. to VSGI standards)
- 9) Secondary sealant (acc. to VSGI standards)

Insulation unit on one or both sides of fire glass unit possible

Tolerances are given in standards or CE documents

\*patterned glass types: SGG SR SILVIT, SGG SR ARENA C, SGG MASTER-POINT, SGG MASTER-LIGNE, SGG MASTER-CARRE, SGG MASTER-RAY, SGG MASTER-LENS

Adhesive/ adherent polyester/ polyethylen terephthalat (PET) or polyvinyle chloride (PVC) films may be applied to the free vision area of a glazed element. They may have a thickness between 25 and 250  $\mu\text{m}$ .

|   |   |  |
|---|---|--|
| <p>This drawing is Copyright©<br/>         Contractors must check all dimensions.<br/>         Any discrepancies must be reported before<br/>         work proceeds.<br/>         Only work to dimensions stated on drawing.</p>  | <p><b>INTERNATIONAL FIRE CONSULTANTS LTD</b></p> <p>20 Park Street Princes Risborough Buckinghamshire HP27 9AH United Kingdom<br/>         Tel: +44 (0) 1844 275500 Fax: +44 (0) 1844 274002 Email: ifc@intfire.com Website: http://www.intfire.com</p> |  |
| <p>Field of Application Report IFCA/08016<br/>         Vetrotech Saint-Gobain Int. AG<br/>         Contraflam Lite 30 Glass Panes, Single &amp; IGU's,<br/>         with Various Dimensions &amp; Glass Thicknesses for<br/>         30 Minutes Integrity &amp; Radiation Performance</p> | <p>SGG Contrflam Lite 30<br/>         (Insulating Glass Unit Acc. To EN 1279)<br/>         Glass Description</p>  | <p>Job number: 7652<br/>         Drawn by: CSP Checked by: CM<br/>         Not To Scale March 2008<br/> <span style="font-size: 1.5em; font-weight: bold;">08016/05</span></p> |

## Maximum Height & Width - Contraflam Lite 30

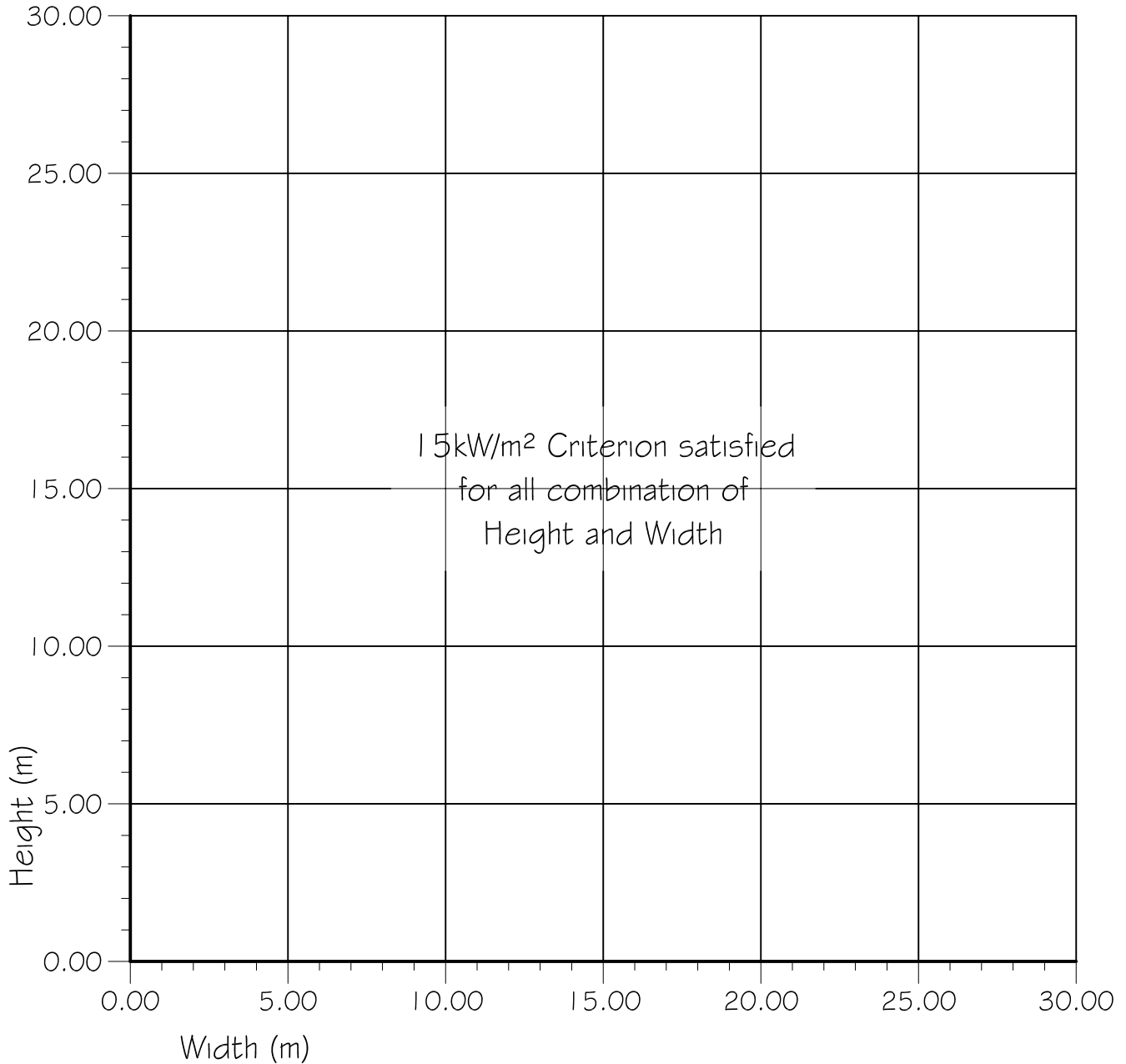

|   |  |                  |  |               |                |              |            |          |  |
|---|--|------------------|--|---------------|----------------|--------------|------------|----------|--|
| <p>This drawing is Copyright©<br/>Contractors must check all dimensions.<br/>Any discrepancies must be reported before<br/>work proceeds.<br/>Only work to dimensions stated on drawing.</p>  | <hr style="border: 1px solid black;"/> <h3 style="margin: 0;">INTERNATIONAL FIRE CONSULTANTS LTD</h3> <hr style="border: 1px solid black;"/> <p style="margin: 0;">20 Park Street Princes Risborough Buckinghamshire HP27 9AH United Kingdom<br/>Tel: +44 (0) 1844 275500 Fax: +44 (0) 1844 274002 Email: ifc@intfire.com Website: <a href="http://www.intfire.com">http://www.intfire.com</a></p> |                  |  |               |                |              |            |          |  |
| <p>Field of Application Report IFCA/08016<br/>Vetrotech Saint-Gobain Int. AG<br/>Contraflam Lite 30 Glass Panes, Single &amp; IGU's,<br/>with Various Dimensions &amp; Glass Thicknesses for<br/>30 Minutes Integrity &amp; Radiation Performance</p>   | <p style="text-align: center;">15kW/m<sup>2</sup> Radiation Criterion<br/>30 Minute Rating</p>   |                  |  |               |                |              |            |          |  |
| <table style="width: 100%; border-collapse: collapse;"> <tr> <td colspan="2" style="text-align: right; padding: 2px;">Job number: 7652</td> </tr> <tr> <td style="padding: 2px;">Drawn by: CSP</td> <td style="padding: 2px;">Checked by: CM</td> </tr> <tr> <td style="padding: 2px;">Not To Scale</td> <td style="padding: 2px;">March 2008</td> </tr> <tr> <td colspan="2" style="text-align: center; padding: 5px; font-size: 1.2em; font-weight: bold;">08016/06</td> </tr> </table> |  | Job number: 7652 |  | Drawn by: CSP | Checked by: CM | Not To Scale | March 2008 | 08016/06 |  |
| Job number: 7652  |  |                  |  |               |                |              |            |          |  |
| Drawn by: CSP   | Checked by: CM   |                  |  |               |                |              |            |          |  |
| Not To Scale  | March 2008   |                  |  |               |                |              |            |          |  |
| 08016/06  |  |                  |  |               |                |              |            |          |  |

Glass Build Up: 5 - 3 - 5 or 5 - 3 - 5 IGU

SGG Contraflam Lite 30: Thickness  $\geq$  13mm

SGG Contraflam Lite 30 IGU: Thickness  $\geq$  23mm

30 Minutes

Pane sizes within the hatched area are approved for use subject to the requirements in Report IFCA/08016

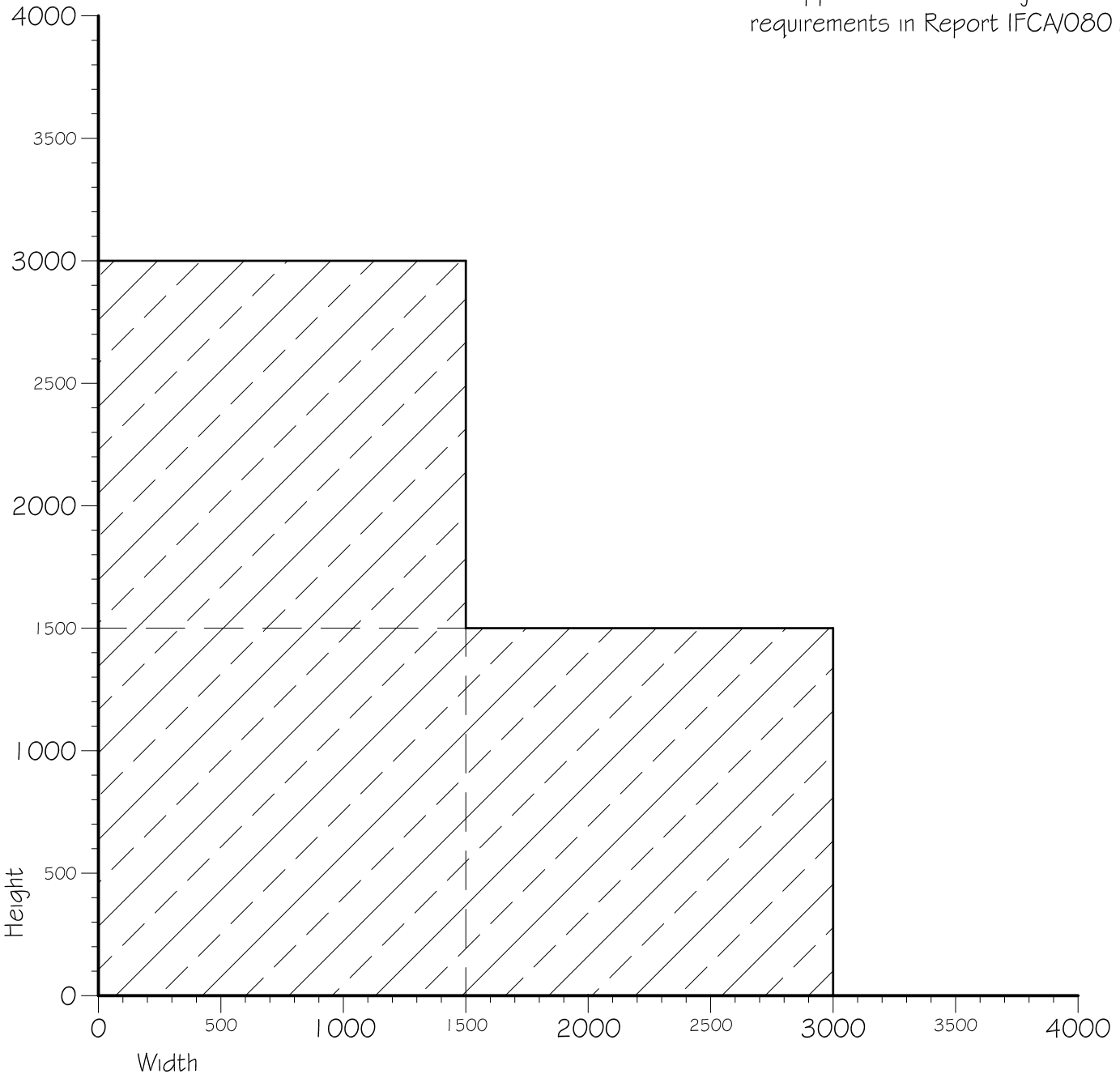

|   |  |  |
|---|--|--|
| <p>This drawing is Copyright©<br/>Contractors must check all dimensions.<br/>Any discrepancies must be reported before<br/>work proceeds.<br/>Only work to dimensions stated on drawing.</p>  | <p><b>INTERNATIONAL FIRE CONSULTANTS LTD</b></p> <p>20 Park Street Princes Risborough Buckinghamshire HP27 9AH United Kingdom<br/>Tel: +44 (0) 1844 275500 Fax: +44 (0) 1844 274002 Email: ifc@intfire.com Website: http://www.intfire.com</p> |  |
| <p>Field of Application Report IFCA/08016<br/>Vetrotech Saint-Gobain Int. AG<br/>Contraflam Lite 30 Glass Panes, Single &amp; IGU's,<br/>with Various Dimensions &amp; Glass Thicknesses for<br/>30 Minutes Integrity &amp; Radiation Performance</p> | <p>Envelope of Approved Pane Sizes for<br/>13mm Thick SGG Contraflam Lite 30 Glass &amp;<br/>23mm Thick SGG Contraflam Lite 30 IGU Glass<br/>With 5 - 3 - 5 Build UP for 30 Minutes Integrity</p>  | <p>Job number: 7652<br/>Drawn by: CSP Checked by: CM<br/>Not To Scale March 2008<br/><b>08016/07</b></p> |

Glass Build Up: 6 - 3 - 6 or 6 - 3 - 6 IGU

SGG Contraflam Lite 30: Thickness  $\geq 15\text{mm}$

SGG Contraflam Lite 30 IGU: Thickness  $\geq 25\text{mm}$

30 Minutes

Pane sizes within the hatched area are approved for use subject to the requirements in Report IFCA/08016

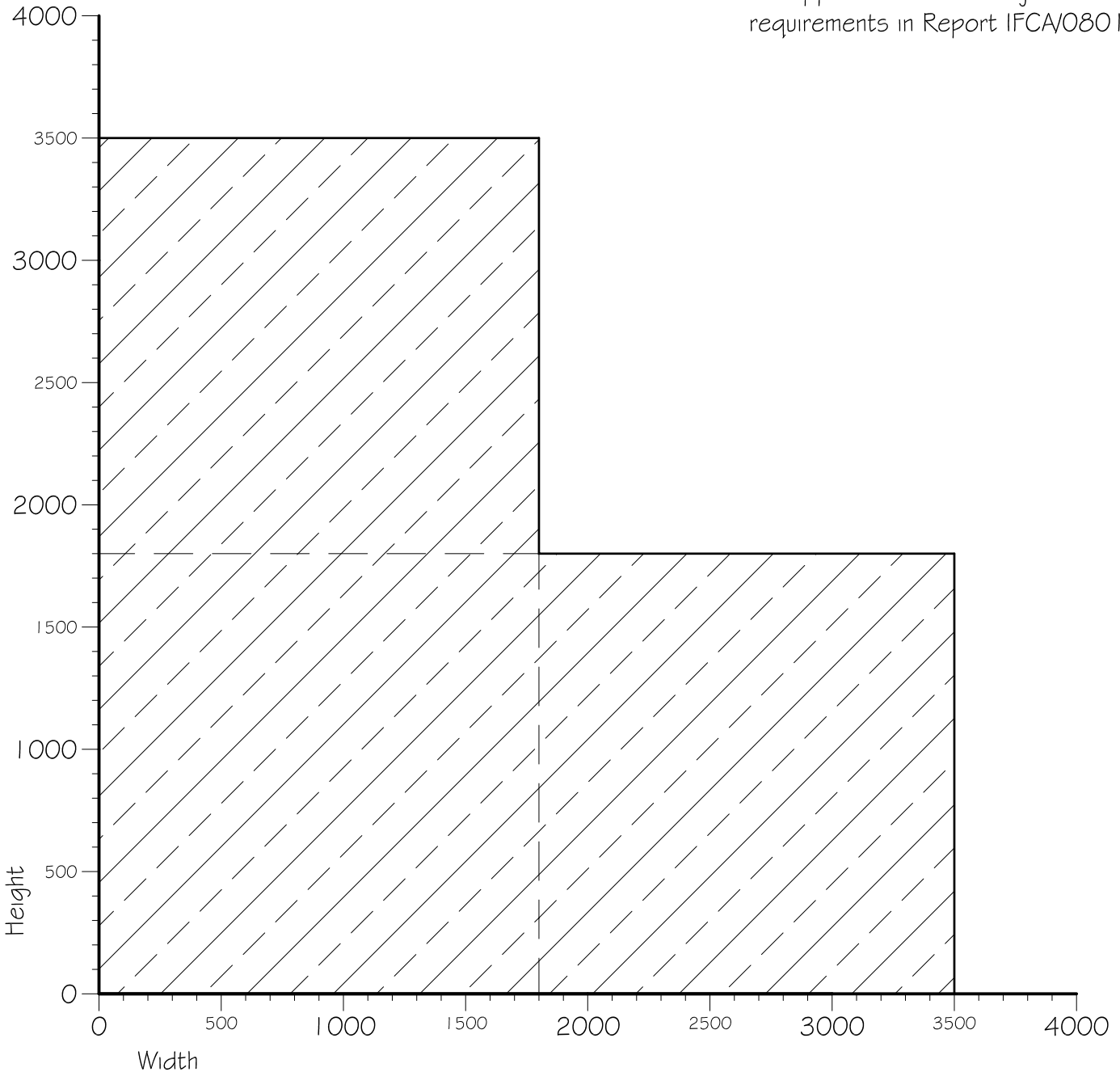

|   |  |  |
|---|--|--|
| <p>This drawing is Copyright©<br/>Contractors must check all dimensions.<br/>Any discrepancies must be reported before<br/>work proceeds.<br/>Only work to dimensions stated on drawing.</p>  | <p><b>INTERNATIONAL FIRE CONSULTANTS LTD</b></p> <p>20 Park Street Princes Risborough Buckinghamshire HP27 9AH United Kingdom<br/>Tel: +44 (0) 1844 275500 Fax: +44 (0) 1844 274002 Email: ifc@intfire.com Website: http://www.intfire.com</p> |  |
| <p>Field of Application Report IFCA/08016<br/>Vetrotech Saint-Gobain Int. AG<br/>Contraflam Lite 30 Glass Panes, Single &amp; IGU's,<br/>with Various Dimensions &amp; Glass Thicknesses for<br/>30 Minutes Integrity &amp; Radiation Performance</p> | <p>Envelope of Approved Pane Sizes for<br/>15mm Thick SGG Contraflam Lite 30 Glass &amp;<br/>25mm Thick SGG Contraflam Lite 30 IGU Glass<br/>With 6 - 3 - 6 Build UP for 30 Minutes Integrity</p>  | <p>Job number: 7652<br/>Drawn by: CSP Checked by: CM<br/>Not To Scale March 2008<br/><b>08016/08</b></p> |

Glass Build Up: 8 - 3 - 8 or 8 - 3 - 8 IGU

SGG Contraflam Lite 30: Thickness  $\geq 19\text{mm}$

SGG Contraflam Lite 30 IGU: Thickness  $\geq 29\text{mm}$

30 Minutes

Pane sizes within the hatched area are approved for use subject to the requirements in Report IFCA/08016

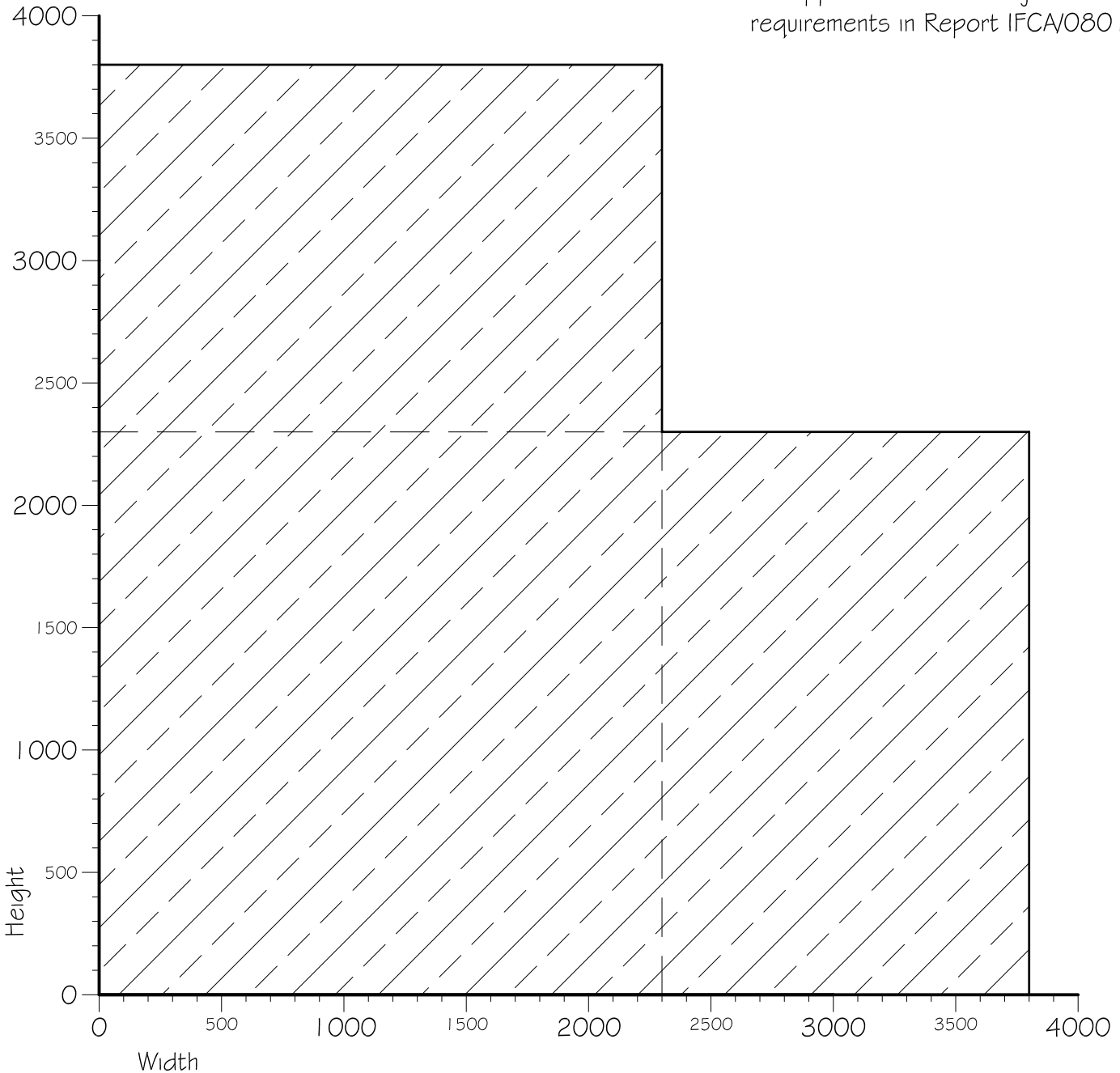

|   |  |  |
|---|--|--|
| <p>This drawing is Copyright©<br/>Contractors must check all dimensions.<br/>Any discrepancies must be reported before<br/>work proceeds.<br/>Only work to dimensions stated on drawing.</p>  | <p><b>INTERNATIONAL FIRE CONSULTANTS LTD</b></p> <p>20 Park Street Princes Risborough Buckinghamshire HP27 9AH United Kingdom<br/>Tel: +44 (0) 1844 275500 Fax: +44 (0) 1844 274002 Email: ifc@intfire.com Website: http://www.intfire.com</p> |  |
| <p>Field of Application Report IFCA/08016<br/>Vetrotech Saint-Gobain Int. AG<br/>Contraflam Lite 30 Glass Panes, Single &amp; IGU's,<br/>with Various Dimensions &amp; Glass Thicknesses for<br/>30 Minutes Integrity &amp; Radiation Performance</p> | <p>Envelope of Approved Pane Sizes for<br/>19mm Thick SGG Contraflam Lite 30 Glass &amp;<br/>29mm Thick SGG Contraflam Lite 30 IGU Glass<br/>With 8 - 3 - 8 Build UP for 30 Minutes Integrity</p>  | <p>Job number: 7652<br/>Drawn by: CSP Checked by: CM<br/>Not To Scale March 2008<br/><b>08016/09</b></p> |

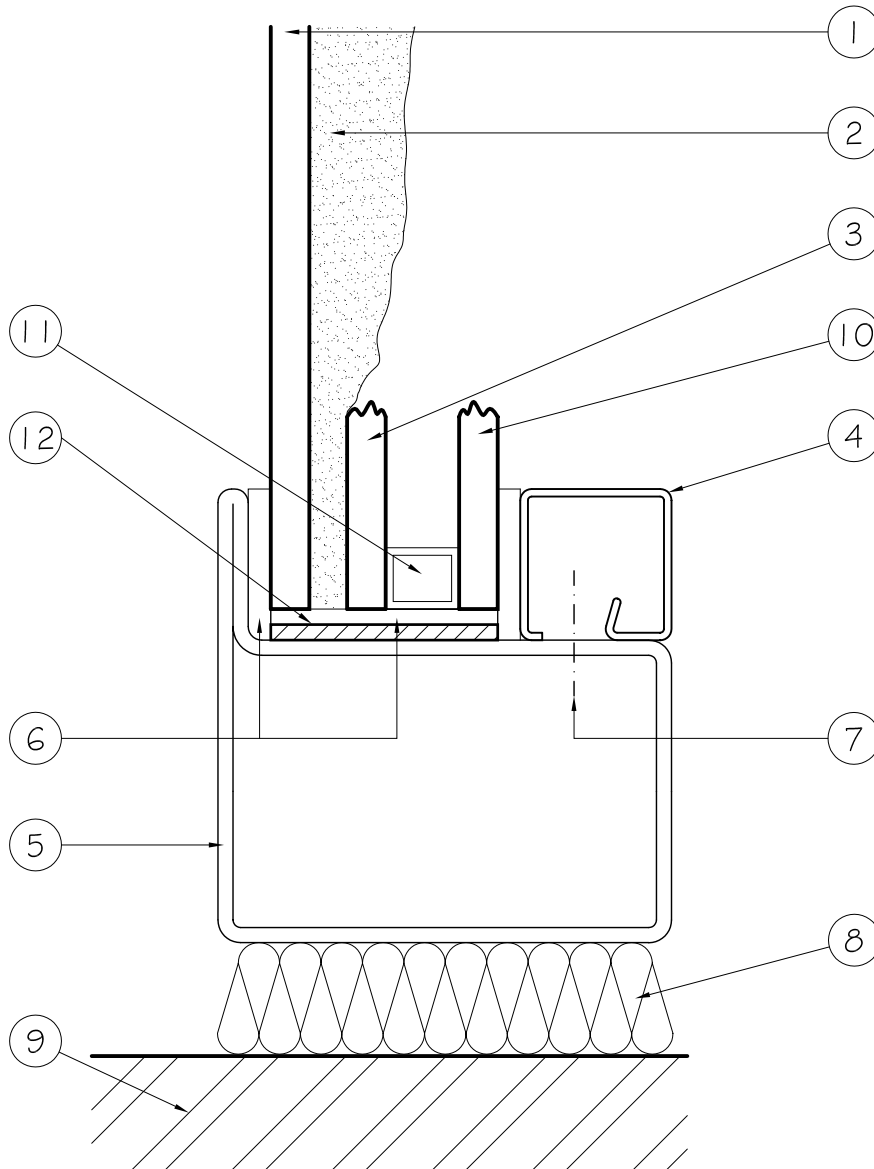

|   |  |  |
|---|--|--|
| <p>This drawing is Copyright©<br/>Contractors must check all dimensions.<br/>Any discrepancies must be reported before<br/>work proceeds.<br/>Only work to dimensions stated on drawing.</p>  | <p><b>INTERNATIONAL FIRE CONSULTANTS LTD</b></p> <p>20 Park Street Princes Risborough Buckinghamshire HP27 9AH United Kingdom<br/>Tel: +44 (0) 1844 275500 Fax: +44 (0) 1844 274002 Email: ifc@intfire.com Website: http://www.intfire.com</p> |  |
| <p>Field of Application Report IFCA/08016<br/>Vetrotech Saint-Gobain Int. AG<br/>Contraflam Lite 30 Glass Panes, Single # IGU's,<br/>with Various Dimensions &amp; Glass Thicknesses for<br/>30 Minutes Integrity &amp; Radiation Performance</p> | <p>Contraflam Lite<br/>DGU during fire exposure<br/>as tested in IFCI/544</p>  | <p>Job number: 7652<br/>Drawn by: CSP Checked by: CM<br/>Not To Scale March 2008<br/><b>08016/10</b></p> |

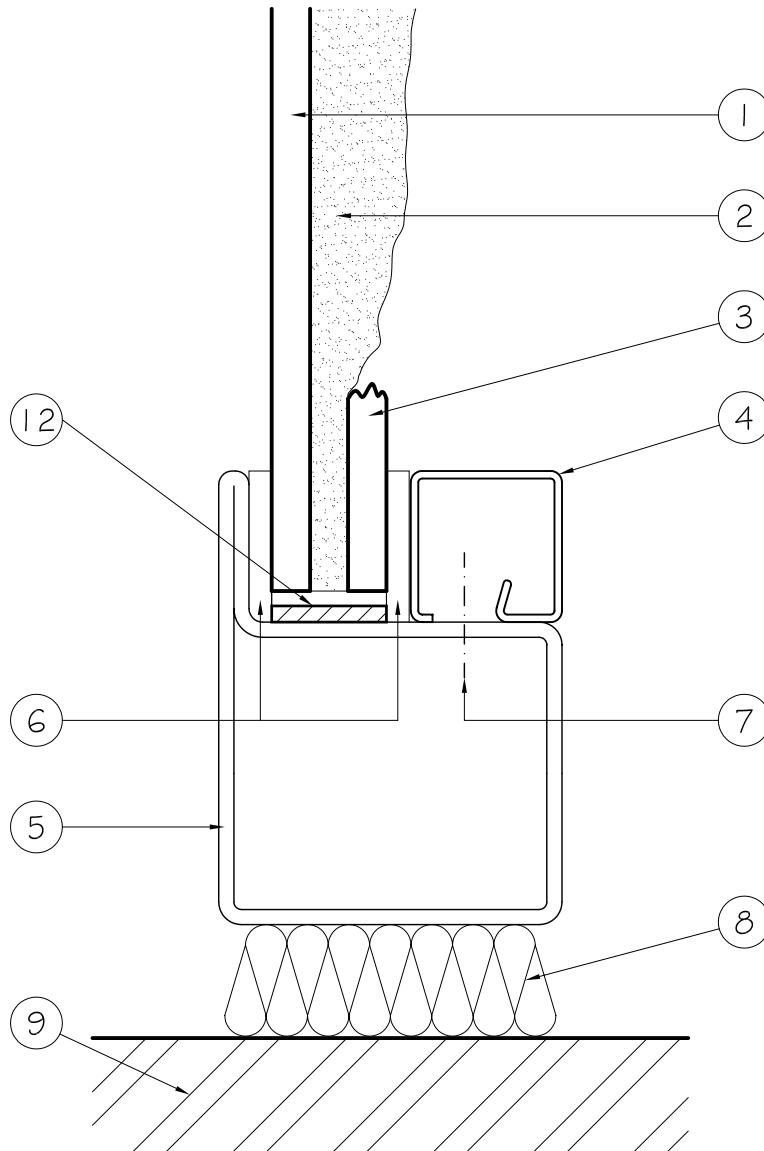

|   |  |  |
|---|--|--|
| <p>This drawing is Copyright©<br/>Contractors must check all dimensions.<br/>Any discrepancies must be reported before<br/>work proceeds.<br/>Only work to dimensions stated on drawing.</p>  | <p><b>INTERNATIONAL FIRE CONSULTANTS LTD</b></p> <p>20 Park Street Princes Risborough Buckinghamshire HP27 9AH United Kingdom<br/>Tel: +44 (0) 1844 275500 Fax: +44 (0) 1844 274002 Email: ifc@intfire.com Website: http://www.intfire.com</p> |  |
| <p>Field of Application Report IFCA/08016<br/>Vetrotech Saint-Gobain Int. AG<br/>Contraflam Lite 30 Glass Panes, Single &amp; IGU's,<br/>with Various Dimensions &amp; Glass Thicknesses for<br/>30 Minutes Integrity &amp; Radiation Performance</p> | <p>Contraflam Lite<br/>Single pane during fire exposure</p>  | <p>Job number: 7652<br/>Drawn by: CSP Checked by: CM<br/>Not To Scale March 2008<br/><b>08016/11</b></p> |

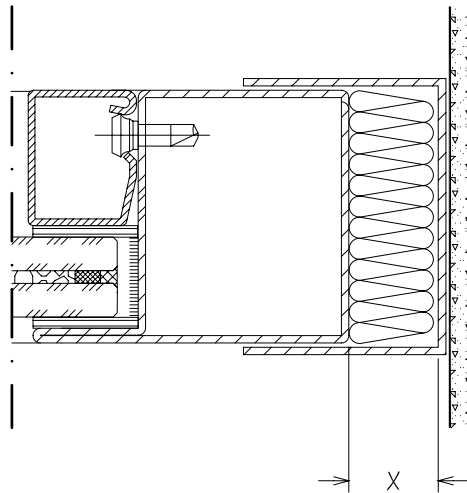

This drawing is Copyright©  
 Contractors must check all dimensions.  
 Any discrepancies must be reported before  
 work proceeds.  
 Only work to dimensions stated on drawing.

## INTERNATIONAL FIRE CONSULTANTS LTD

20 Park Street Princes Risborough Buckinghamshire HP27 9AH United Kingdom  
 Tel: +44 (0) 1844 275500 Fax: +44 (0) 1844 274002 Email: ifc@intfire.com Website: <http://www.intfire.com>

Field of Application Report IFCA/08016  
 Vetrotech Saint-Gobain Int. AG  
 Contraflam Lite 30 Glass Panes, Single & IGU's,  
 with Various Dimensions & Glass Thicknesses for  
 30 Minutes Integrity & Radiation Performance

Expansion Detail

Job number: 7652

|               |                |
|---------------|----------------|
| Drawn by: CSP | Checked by: CM |
| Not To Scale  | March 2008     |

08016/12